

RoHS

ウェッジコンタクト

WEDGE CONTACT

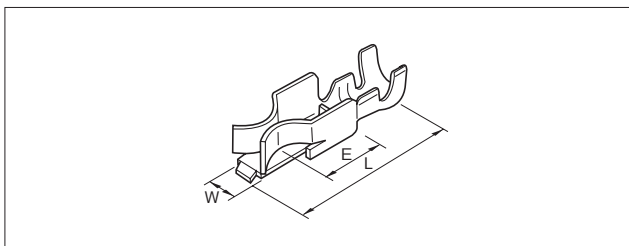

品番 Part No.	電線サイズ Wire Size		材質 Material	板厚 Thickness	L	W	E	個数/リール PCS/Reel	アプリケーション Applicator	備考 Reference
	AWG	断面積(mm ²) Sectional area(mm ²)								
415518-0A	#16~#20	0.5~1.25	黄銅 Brass	0.32	12.2	5.3	10.5	3,000×5R	TJS-03200	

ヒューズ用φ6.5

FUSE TERMINAL φ6.5

RoHS

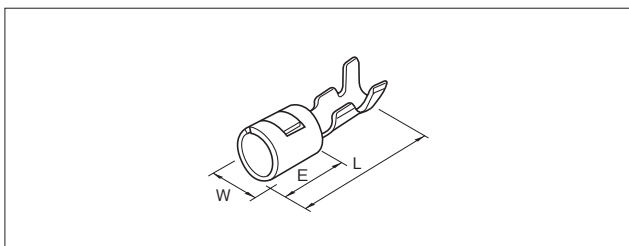

品番 Part No.	電線サイズ Wire Size		材質 Material	板厚 Thickness	L	W	E	個数/リール PCS/Reel	アプリケーション Applicator	備考 Reference
	AWG	断面積(mm ²) Sectional area(mm ²)								
365802-2M	#14~#20	0.5~2.0	黄銅 Brass	0.4	16.6	6.8	6.6	1,800×4R	MCS-13400	

RoHS

ボタンφ4

BUTTON TERMINAL φ4

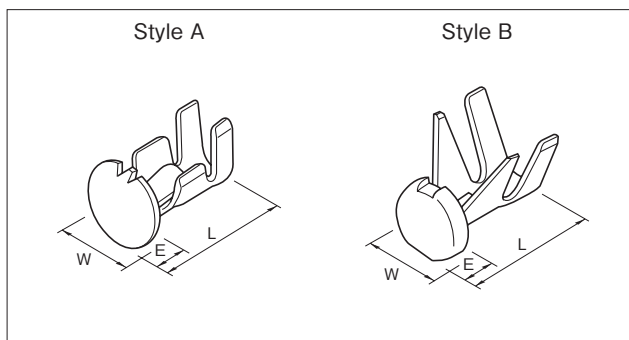

品番 Part No.	形状 Style	電線サイズ Wire Size		材質 Material	板厚 Thickness	L	W	E	個数/リール PCS/Reel	アプリケーション Applicator	備考 Reference
		AWG	断面積(mm ²) Sectional area(mm ²)								
400412-0	A	#18~#22	0.3~0.85	黄銅 Brass	0.4	7.0	4.6	1.7	8,000×6R	MCS-1800	
400414-0	B	#16~#20	0.5~1.25	黄銅 Brass	0.4	6.9	4.6	1.6	8,000×5R	MCS-9600	
400417-0	A	#18~#20	0.5~0.85	黄銅 Brass	0.4	6.9	4.6	1.6	8,000×5R	MCS-20400	

注) 表面処理については「表面処理分類表(P225)」を参照ください。

Notice) Finishing code is available to see attached "Finishing Classification(P225)"