

第三角法
3rd ANGLE PROJECTION

単位: mm 注) . . . 図面を実測しないこと
UNIT: mm NOTES) . . . DO NOT SCALE

図番 DRAWING No.
JC-0947-19

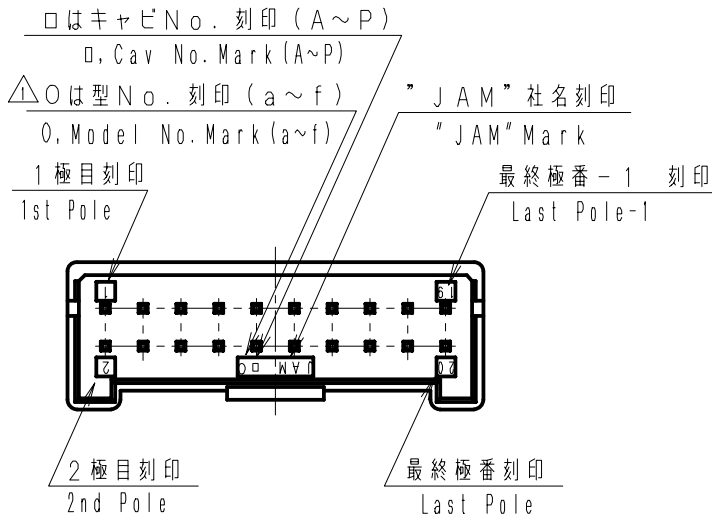

Poles	A	B
8	6.0	10.0
10	8.0	12.0
12	10.0	14.0
14	12.0	16.0
16	14.0	18.0
18	16.0	20.0
20	18.0	22.0

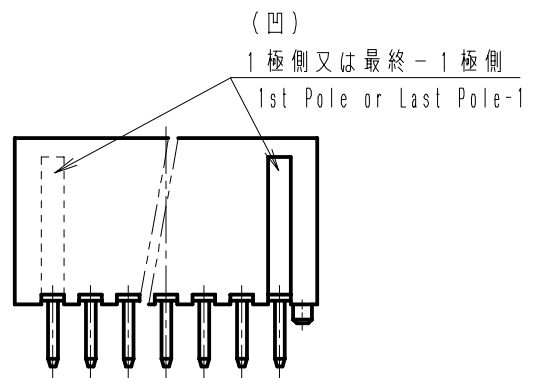
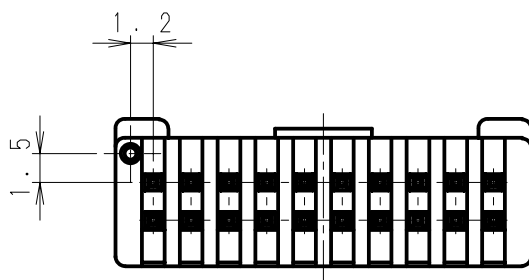
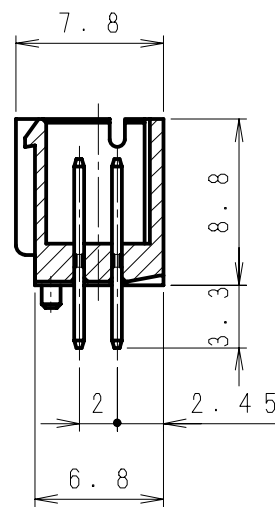
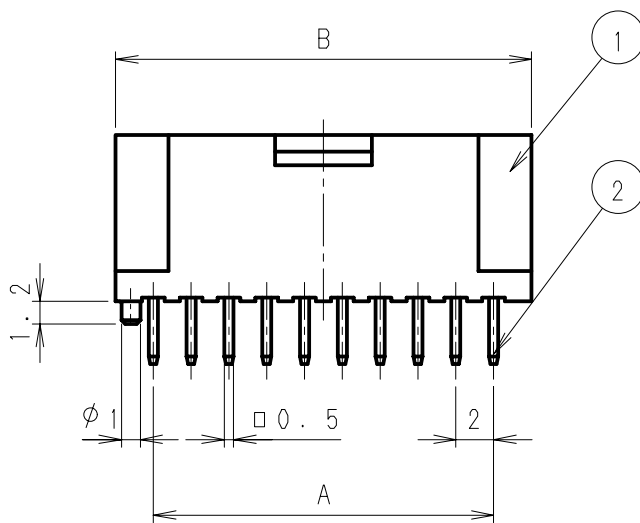

△6	. .								
△5	. .								
△4	. .								
△3	. .								
△2	12.11.14	アイテム追加 (8P) Item add. (8P)	清水	草野	製品番号 PRODUCT No.	②	黄銅 Brass	錫メッキ材 Tin Plating	
△1	06.12.18	金型刻印No.追加 Model No. mark addition	清水	堀内		No.	①	ナイロン66 (GF入) Nylon66 (GF)	
記号 No.	年月日 DATE	変更記事 REVISION RECORD	設計 DESIGN	承認 APP			材 料 MATERIAL	備考 NOTE	色 COLOR
記号 No.	年月日 DATE	変更記事 REVISION RECORD	設計 DESIGN	承認 APP			製品名 NAME	SJWウエハー (ストレート型) SJW Wafer (Straight type)	
承認 APPROVED	確認 CHECKED	一般公差 TOLERANCE	尺度 SCALE	図番 DRAWING No.					
Y. Horiuchi	Y. Horiuchi	±0.3	2.5/1	JC-0947-19					
設計 DESIGN	製図 DRAWING	J.A.M. JAPAN AUTOMATIC MACHINE CO., LTD.							
K. Kusano	K. Kusano								